

**Mosaic™**  
**Two-way switches 10 AX - antimicrobial**

Cat. No(s): **0 787 10/11/12**  
**0 770 27**

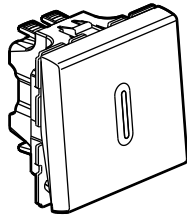

0 787 12

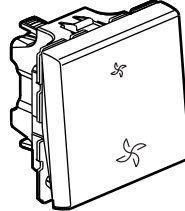

0 770 27

CONTENTS	Page
1. Use . . . . .	1
2. Range . . . . .	1
3. Overall dimensions . . . . .	1
4. Connection . . . . .	1
5. Wiring . . . . .	1-2
6. Technical characteristics. . . . .	2
7. Cleaning . . . . .	3
8. Accessories . . . . .	3
9. Standards and approvals . . . . .	3

**1. USAGE**

Lighting mechanisms with or without marking elements (LED indicator) control.

This technology eliminates bacteria, fungi and viruses without creating any immunisation or resistance effects (physical, rather than chemical, destruction).

Particularly suitable for healthcare establishments (hospitals, clinics, nursing homes, laboratories, waiting rooms, etc.) and more generally for areas subject to hygiene restrictions (industrial, shared and restaurant kitchens, waste, etc.).

These products offer an additional way of ensuring the non-proliferation of bacteria, fungi and viruses without interfering with cleaning protocols. Flush or surface mounting.

To be equipped with plates.

**2. RANGE**

	Description	Cat. No.
	Two-way switch - 1 module	0 787 10
	Two-way switch - 2 modules	0 787 11
	Two-way switch with LED indicator Equipped with a terminal for neutral connection To be equipped with an indicator 2 modules	0 787 12
	Two-way switch for direct control of controlled mechanical ventilation. 2 modules	0 770 27

**3. OVERALL DIMENSIONS (mm)**

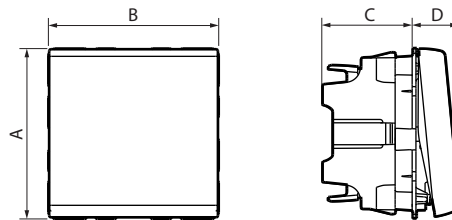

References	A	B	C	D
0 787 10	45	22.5	24	12.3
0 787 11/12 - 0 770 27	45	45	24	12.3

**4. CONNECTION**

Type of terminals: automatic  
 Terminal capacity: 2 x 2.5 mm<sup>2</sup>  
 Stripping length: 13 mm

**5. WIRING**

**Reference: 0 787 12**

**Illuminated function:** Illuminates the switch in the dark.

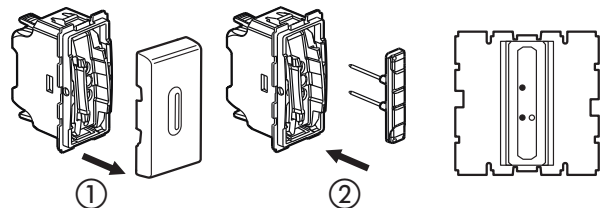

- 1 - Unclip the rocker
- 2 - Insert the indicator light Cat. No. 0 676 86 or Cat. No. 0 676 87

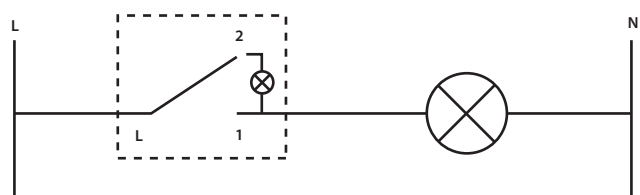

5. WIRING (continued)

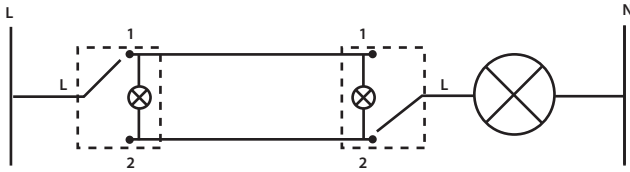

Two-way switch with an indicator

**Indicator function:** The lamp is switched on when the lighting is on.

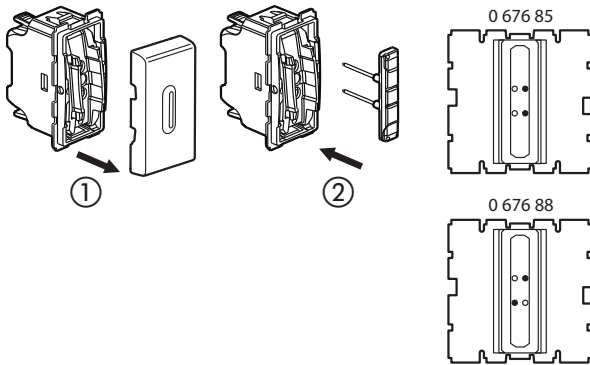

- 1 - Unclip the rocker
- 2 - Insert the indicator lamp Cat. No. 0 676 88 or 0 676 85

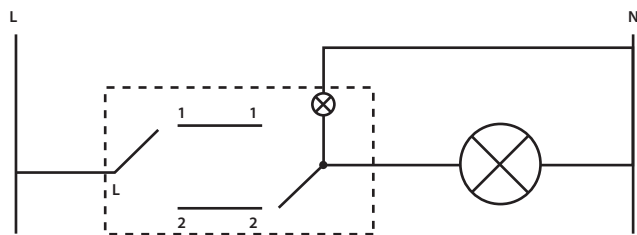

Two-way switch existing cabling

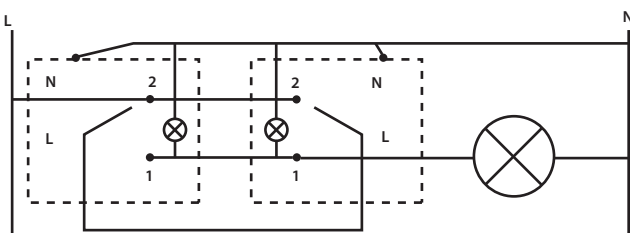

Two-way switch

6. TECHNICAL CHARACTERISTICS

■ 6.1 Mechanical characteristics

Impact tests: IK 04  
Protection against solid bodies and liquids: IP 31 D  
**Nota :** Switching mechanism (handling force 2.6 to 3.5 N).

■ 6.2 Material characteristics

- Cover plate: Polycarbonate (RAL 9003) + antimicrobial treatment

	Reduction factor
Aspergillus niger	Log 0.04
Bacillus cereus	Log 0.44
Bacillus subtilis	Log 0.13
Candida albicans	Log 1.11
Enterovirus Polio 1	Log 0.2
Escherichia Coli	Log 4.7
Myobacterium Avium	Log 1.61
Myobacterium Terrae	Log 1.45
Pseudomonas aeruginosa	Log 5.8
Staphylococcus aureus	Log 4.02

Cat. No. 0 787 12: Polycarbonate + antimicrobial surface treatment:

	Reduction factor
Aspergillus niger	Log 0
Bacillus cereus	Log 0.05
Bacillus subtilis	Log 0.09
Candida albicans	Log 0.86
Enterovirus Polio 1	Log 1
Escherichia Coli	Log 6.3
Myobacterium Avium	Log 0.04
Myobacterium Terrae	Log 1.21
Pseudomonas aeruginosa	Log 4.4
Staphylococcus aureus	Log 2.67

**NB:** log 4 = 99.99% ; log 3 = 99.9% ; log 2 = 99% ; log 1 = 90%

Tests carried out in accordance with standards JIS Z 2801: 2000 and JIS Z 2801: 2006

Test report available on request.

- Base: PC
- Rockert: PC
- Halogen free
- UV resistant
- Self-extinguishing:
- + 850°C / 30 s for insulating components holding in place live parts.
- + 650°C / 30 s for the other insulating components.

■ 6.3 Electrical characteristics

Voltage: 250 VAC  
Current: 10 AX

■ 6.4 Climatic characteristics

Storage temperature: - 10° C to + 70° C  
Operating temperature : - 5° C to + 5 0° C

## 7. CLEANING

Surface cleaning with a cloth.  
Do not use: acetone, tar remover, trichloroethylene.

### ■ 7.1 Resistance to cleaning agents

Resistance to the following agents: Hexane (EN 60669-1), methylated spirits, soapy water, diluted ammonia, pure bleach diluted 10%, glass cleaning substance, pre-impregnated wipe.

### ■ 7.2 Resistance to hospital-type cleaning agents

Resistance to the following agents: Anios, Surfanios, Bactylsine, Diluted hydrogen peroxide (35%).

**Caution:** A preliminary test should be carried out if other specific cleaning products are to be used.

## 8. ACCESSORIES

Lights for switches with indicator light 0 787 12:

Illuminated	0 676 86 (230 V - 0,15 mA)
	0 676 87 (12-24-48 V)
Indicator	0 676 85 (230 V - 3 mA)
	0 676 88 distributed phase (230 V - 3 mA)

## 9. CONFORMITY AND APPROVALS

Compliance with standards of installation and manufacturing.  
See e.catalogue.