

Frame supports for the fixing of the Chorus modular devices, made in technopolymer and characterized by ribs that reinforce the structure and ensure high performances. The range includes versions for the mounting with plates for rectangular boxes and capacity up to 12 modules, versions for the mounting with international plates for round/square boxes and versions for DIN rail mounting. They fit in flush-mounting or wall-mounting boxes and are equipped with fixing system based on screws or clutches. The practical way of assembly/release from the front of the frame supports of the Chorus modular devices also allows to mount devices with modularity of 1/2, 1, 2 and 3 modules.

Characteristics	Halogen free	Fixing	2 screws (included)
Description	3 gang	For box	3P
Electrocod	0121	Glow wire test	650 °C
Thermo-pressure with ball	75 °C	Standard	EN 60669-1

DIMENSIONAL

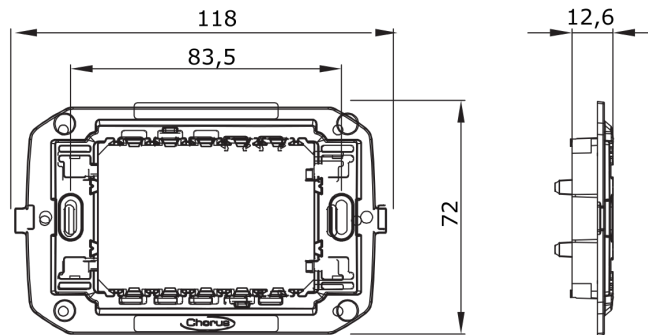

TECHNICAL SYMBOLOGY

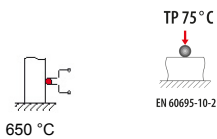

STANDARDS/APPROVALS



GEWISS S.p.A. Via A. Volta, 1
24069 Cenate Sotto - Bergamo - Italy
tel. +39 035 94 61 11 fax +39 035 94 69 09

www.gewiss.com
sat@gewiss.com
Last update 17/05/2016

Data, measures, designs and pictures are shown only as informativ purposes, and could be changed without previous notice