

Wiring device system specific for installations in round and square boxes, characterized by an elegant appearance and classic shapes. The plates, realized in technopolymer in seven colors and in different modularities, from 2 up to 2+2+2+2 gang, are installable indifferently in horizontal or in vertical position. The range, developed around a core of monobloc devices, is available in two colors: white and ivory, in glossy finish. Expandable thanks to the Chorus modular devices.

Colour	Ivory	Material	Technopolymer
Type	General	Finishing	Glossy
Fixing	With clutches/Screws	Description	Double 1P - 10 AX
Type of terminals	Screwless	Breaking capacity (EN 61009-1)	1.25 In (200 position changes)
Voltage	250 V ac	Terminal tightening capacity	0,5-2x2,5 mm ² fils rigides
Glow wire test	850 °C	Category	Double two-way switch
Insulation resistance	> 5 MOhm	Thermo-pressure with ball	125 °C
Standard	EN 60669-1	Resistance at test voltage	2000 V a 50 Hz for 1 minut
Prolonged operation (no.of position changes)	40.000 at In 250 V ac cos=0,6	Terminal grip on cable traction	30 N

DIMENSIONAL

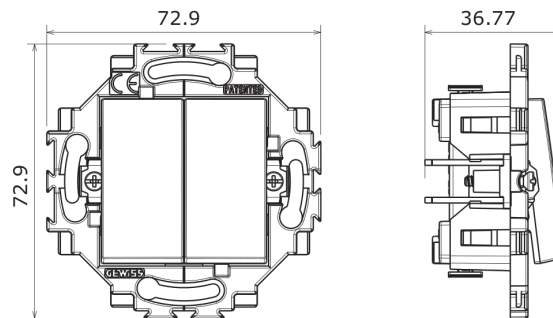

TECHNICAL SYMBOLOGY

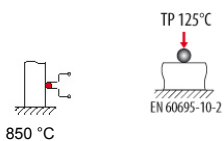

STANDARDS/APPROVALS



GEWISS S.p.A. Via A. Volta, 1
24069 Cenate Sotto - Bergamo - Italy
tel. +39 035 94 61 11 fax +39 035 94 69 09

www.gewiss.com
sat@gewiss.com
Last update 23/06/2016

Data, measures, designs and pictures are shown only as informativ purposes, and could be changed without previous notice