

Wiring device system specific for installations in round and square boxes, characterized by an elegant appearance and classic shapes. The plates, realized in technopolymer in seven colors and in different modularities, from 2 up to 2+2+2+2 gang, are installable indifferently in horizontal or in vertical position. The range, developed around a core of monobloc devices, is available in two colors: white and ivory, in glossy finish. Expandable thanks to the Chorus modular devices.

<b>Colour</b>	White	<b>Characteristics</b>	With shutters for child protection
<b>Material</b>	Technopolymer	<b>Finishing</b>	Glossy
<b>Fixing</b>	With clutches/Screws	<b>For plug pins</b>	Ø 4 / 4.8 mm
<b>Standard</b>	French standard	<b>Description</b>	2P+E - 16A
<b>Type of terminals</b>	Screwless	<b>Breaking capacity (EN 61009-1)</b>	1.25 In (100 position changes)
<b>Voltage</b>	250 V ac	<b>Terminal tightening capacity</b>	0,5-2x2,5 mm <sup>2</sup> fils rigides
<b>Glow wire test</b>	850 °C	<b>Category</b>	Socket-outlet
<b>Insulation resistance</b>	> 5 MOhm	<b>Thermo-pressure with ball</b>	125 °C
<b>Standard</b>	IEC 60884-1	<b>Resistance at test voltage</b>	2000 V a 50 Hz for 1 minut
<b>Prolonged operation (no.of position changes)</b>	10.000 at In 250 V ac cos=0,8	<b>Terminal grip on cable traction</b>	30 N

### DIMENSIONAL

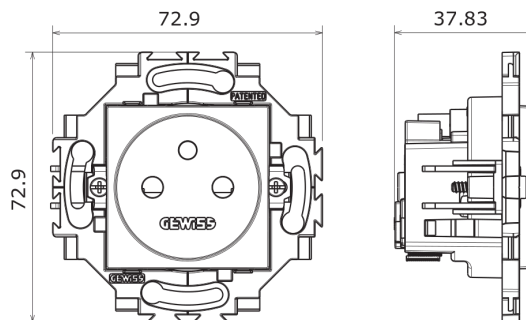

### TECHNICAL SYMBOLOGY

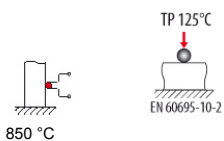

### STANDARDS/APPROVALS

GEWISS S.p.A. Via A. Volta, 1  
24069 Cenate Sotto - Bergamo - Italy  
tel. +39 035 94 61 11 fax +39 035 94 69 09

www.gewiss.com  
sat@gewiss.com  
Last update 23/06/2016

Data, measures, designs and pictures are shown only as informativ purposes, and could be changed without previous notice